



IMPACT PULVERIZER

AUTO SUCTION HAMMER MILL

HAMMER MILL

BOTTOM DISCHARGE HAMMER MILL

SPICE MILL

POUNDING MACHINE

FOUR HAMMER POUNDING MACHINE

DRY & WET PULVERIZER



WET PULVERIZER

MINI PULVERIZER

JACKETED MINI PULVERIZER

BLACK PEPPER DAL MAKING MACHINE

MULTI CAMBER PULVERIZER

MINI DAL MILL

EMERY SCOURER

DAL POLISHER

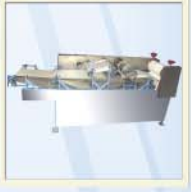

VIBRO SREEN

CENTRIFUGAL SIEVES / SIFTER

RIBBON BLENDER

SINGLE PADDLE MIXER 'U' TYPE

DOUGH KNEADER

SEMI AUTOMATIC CHAPATI MAKING M/C

RAW CHAPATI MAKING MACHINE

AUTOMATIC CHAPATI MAKING MACHINE



NOODLE MAKING MACHINE

NOODSLE STEAMING MACHINE

ECONOMIC STEAMER

IDLI DHOKLA MOMOS STEAMER

SHEVAYA MACHINE

VERMICELLI MAKING MACHINE

TRAY DRYER DRYING OVEN

VEGETABLE PEELER



POTATO CHIPS CRISPS MAKING MACHINE

HAND OPERATED POTATO CHIPS MAKING MACHINE

FRENCH FRY MAKING MACHINE

BANANA WAFER MACHINE

RECTANGULAR FRYER

CIRCULAR BATCH FRYER

CONTINUOUS FRYER

COATING PAN



MKEEN MAKING MACHINE

CENTRIFUGAL DRYER MACHINE

DOUGH KNEADER WITH EXTRUDER

PAPAD MAKING MACHINE

CONTINUOUS PAPAD DRYER

PANI PURI MAKING MACHINE

ECONOMIC MIXER GRINDER BLENDER

MIXER GRINDER BLENDER



STIRRER

MULTIPURPOSE VEGETABLE CUTTER

VEGETABLE SLICER, DICER, GREATER

GREEN CHILL ONION CHOPPER

DRY FRUIT TUKDA MACHINE

DRY FRUITS CHIPS MAKING MACHINE

DRY FRUITS CHIPS MAKING M/C WITH MOTOR

MULTIPURPOSE DRY FRU CHIPS & POWDER MACHIN



CENTRIFUGAL JUICER

MASTICATING JUICER

VEGETABLE & FRUIT PULPER

HOT BEVERAGE VENDING MACHINES

Jas ENTERPRISES

AN ISO 9001:2008 CERTIFIED COMPANY

60, SHREENATHJI ESTATE, PANNA ESTATE ROAD, RAKHIAL, AHMEDABAD, GUJARAT - 380025, INDIA
TELEPHONE: +(91)-(79)-22745454 FAX: +(91)-(79)-22745062 GSM: +(91)-9427417384- 9426068680

URL: <http://www.jasenterprise.com/>
E mail: info@jasenterprise.com & jasparvan1990@gmail.com

DE TO CONTINUOUS IMPROVEMENTS, WE RESERVE THE RIGHTS TO ALTER AND OR AMEND DIMENSIONS DESIGN WITHOUT PRIOR NOTICE.

MINI PULVERIZER

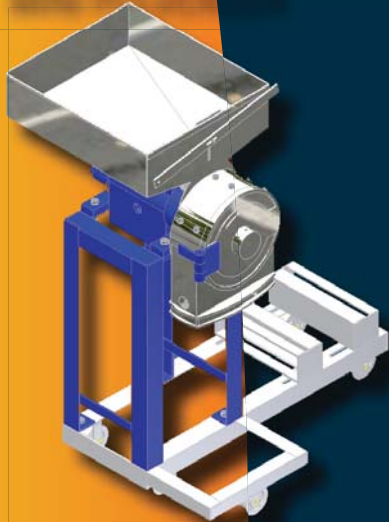

Technically sound designing of mini pulverizer makes it a perfect pulverizer for a crushing target of up to 15 to 80 kilograms per hour. It takes less installation space than normal pulverizer machines and has steel molded body. This ensures unmatched durability and little maintenance. The advanced working methodologies of this pulverizer ensure superior quality of ground material.

The Techno Wings Mini Pulverizer comprises of a heavy duty Mild Steel / Stainless Steel body, which comprises of a feeding hopper, with a feed regulator slide. The pulverizer body is inlaid with a delivery trough attached at the bottom, with a delivery trough attached at the discharged end. The rotor & beater are mounted on shaft, running in a ball bearing housing at a speed of 4500-6000 R.P.M. The whole unit is mounted on a strong steel stand.

Construction of mini pulverizer

Main body & frame is made of high quality cast iron / M. S. frame, liner of high grade steel casting and bearings are lubricated oil (company supplying the machine without oil) Instead of rubber oil seals metal seals are used for avoiding friction & maintenance, which will occur due to the use of rubber seals.

Operating Principal of mini Pulverizer

The flow of material from the feeding hopper is regulating by means of side handle easily to suit the load. Rotor with four cutters runs in anti-clockwise direction. The beaters pass just beneath the ratchet teeth liner fitted inside the top half of the crushing chamber, leaving a gap of 3 mm between the liner teeth and the tips of the rotating beaters. This cuts the material caught between the liner teeth like a sword with a scissors action at a high speed rotations. After the required size reduction, the material will pass through the screen fitted inside the lower discharge end of the pulverizing chamber. No sieving is required, as the appropriate size screen fitted will not allow coarser material to pass through. The air generated in the crushing chamber forces the powder to pass through the screen fitted at the bottom discharge end of the crushing chamber, into a filter attached to the delivery trough below. (When crushing Wet-Pulpy materials, the balloon should not be use)

Servicing guidelines of mini pulverizer

Open the cover of chamber all pulverizing parts cleaned with a brush in couple of minute and the Pulverizer is ready for next crushing. If required, the grinding chamber can also be wash with water. Remove the cotton balloon and the screen, close the cover tightly and start the grinder. Now pour a bucket or two of water into the hopper. The grinding parts will be flushed with the water and cleaned. Continue running the machine for a few more minutes as the draft of the fresh air sucked into the grinder will dry it. The beater when worm out removed and reserved by removing the cur clip lock holding to the rotor pins. When both the edges are worm out, they sharpened on an emery stone, to be use as new. In addition, when completely warn out, replaced the equal weight and refitted.

Typical Application of mini pulverizer

The Techno Wings mini pulverizers are widely used for grinding of both dry/wet spices, green chilly, fresh ginger, garlic, fresh fruits, vegetables. These pulverizer machine can also be used as a fruit finisher. The techno wings Mini Pulverizer can also be used for the following dry applications like agricultural chemicals, broken biscuits, custard powder, coffee, charcoal, dals, dyes & pigments, fillers, henna leaves, herbs, leaves and roots instant foods insecticides and pesticides, kaolin molding powders, pharmaceuticals, plastics, poultry feed & marine feed, resins, sugar (biscuit grade/icing grade), Stearates, tea etc

Outstanding Features of mini pulverizer

- Unique and Reliable Design
- The mini series pulverizers are highly effective as well as non stop continuous pulverizing process.
- Compact size
- Interchangeable & reversible joint less hardened beater thus, the pulveriser will last a life time with minimum replacements
- Dust free operation
- Grinding is carried out in a cool atmospheric temperature, which guarantee against thermal degradation of product quality and flavors.

Rugged Construction of mini pulverizer

Techno wings brand mini pulveriser is made from specially selected materials. The beater are interchangeable and reversible thus, the pulveriser will last for a life time with minimum replacement of parts. Mini pulverizer is Made from Cast Iron body. Grinding Chamber lined with serrated wear plates, which protects the body from wear and tear. Grinding done by a set of swinging four numbers inter changeable and reversible beater on a balanced rotor which is fitted on a shaft. Shaft is fixed with a suitable deep groove ball bearings which is continuously lubricated by oil. This shaft is run by driven pulley and A screen classifier forms the lower half of the grinding chamber.

Technical Specifications of Mini Pulverizer

Model No	TW-MP-4	TW-MP-5	TW-MP-6
Chamber Size (Ø= Diameter X width)	Ø 200 mm X 75 mm	Ø 250 mm X 100 mm	Ø 300 mm X 150 mm
Pulverizer's RPM	4500 to 6000	4500 to 6000	4500 to 6000
Motor HP (KW.)	2 HP (1.5 kW.) Or 3 HP (2.2 Kw.)	5HP (3.7 kW.) Or 7.5 HP (5.6 kW)	7.5 HP (5.6 kW.) Or 10 HP (7.5 kW.)
Fineness Range		2 to 100 B.S.S. Mesh	

Note:- Economic Models are also available.

Standard Accessories of Mini Pulverizer

- One number cotton Balloon
- Five numbers of different size holes screen for getting different mesh powders.

Extra Accessories of Mini Pulverizer

- Three meter suitable cable along with ampere meter & miniature circuit breaker & Suitable totally enclosed fan cooled three phase or Single Phase Squirrel cage motor {Electricity (Special power can be accommodated): 220/380/415 Volts, 50/60 Hz, 1/3 Phase }
- All contacting parts Stainless steel 304 / 316 can be accommodated

NOW ECONOMIC MODELS ARE AVAILABLES.

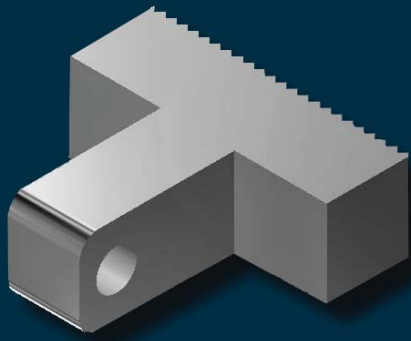

Dynamically balance
interchangeable & reversible joint-
less hardened beater